

Multifiber Push-On (MPO) Connectors Deliver High Performance Across the Network



To stay ahead of customers' demand for bandwidth, service providers must continue to add fiber to their networks and accelerate the speeds at which traffic moves across those infrastructures. As they do so, they are looking for ways to reduce the overall cycle time required to expand network capacity and to ensure they can deliver service with "five 9s" of reliability. Many leading service providers have discovered the plug-and-play multifiber push-on (MPO) connector helps them achieve both objectives.



12-Fiber MPO Cable Assembly

First introduced over 10 years ago, the MPO connector has evolved significantly over time, as companies like TE have re-designed and re-engineered their MPO products and processes. TE, for example, not only has radically improved its MPO connector but also combined it with an innovative cable design to make MPO's easier to install. The result is a next-generation, carrier-grade MPO assembly which has proven, in both laboratory tests and field deployments, that it can satisfy—and in many cases exceed—the IEC 61753-1 requirements for single and multifiber connectors. In fact, MPO connectors are used around the world today to support not only multiple-dwelling unit (MDU) applications but also those in the core network, including central offices, switching centers, data centers, radio network controllers, base station controllers and cell sites.

Designing the Next-Generation, High-Performance MPO Connector

As networks have ramped up to ever-higher data rates over the past decade, some service providers have sometimes been hesitant to adopt new connector technologies. They want to make sure any new connector has a proven track record showing that it can deliver the optical performance and mechanical reliability necessary to support high-speed networks. MPO connectors now fall into this category.

Mindful of service providers' needs for products designed to keep pace with their evolving networks, the industry set out to enhance the performance and reliability of the MPO connector. TE, for example, embarked on an aggressive program to improve optical performance and reliability of the MPO. They did this by, first, improving the connector polishing process, then completely re-designing the back end of the connector. And finally, TE combined the connector with a high-density, small-form-factor cable containing bend-insensitive fiber. To achieve better optical performance, greater durability in the field and improved assembly quality, the design changes specifically include:

- material changes to ensure reliable performance across a wide temperature range as specified in IEC 61755-3-31
- extensively researching and refining the polishing process to achieve consistent low loss across all 12 fibers and
- replacing the flat ribbon cable assembly (for example, 0.178 inches x 0.08 inches) and its standard fiber with a round 3-mm cable utilizing single reduced bend radius fibers

Improved Connector Design

TE improved the design of the MPO connector in three major areas, the first of which is the use of an improved polymer material, a major technological step forward, compared with previous generations. Secondly, a state-of-the-art manufacturing process focuses on updated polishing techniques, which ensures lower return loss across all fibers, and an integrated inspection procedure--no MPO

leaves the factory before having been visually inspected, cleaned and tested for performance verification. This revised manufacturing process ensures optimal connector performance and reliability in the network.

Third, the MPO connector design satisfies the rigorous requirements of IEC 61753-1: it meets the reliability requirements of the SC connector, which service providers use throughout the network; it is designed to perform in harsh environments, and will accommodate a range of temperature extremes from -40°C to +70°C; and when used indoors, the newly-designed connector has proven its ability to exceed specified requirements.

The improved connector design offers service providers a more robust solution for their networks. Simply put, today's MPO connector is less susceptible to failure than earlier versions. Previous MPO connectors, which utilized flat, ribbonized cable, had significant bend limitations. The flat cable-type and boot design served to handle only moderate pull forces above or below the connector, and offered very little protection from side pull forces. For example, when a technician pulled on an MPO connector or wiggled it during installation, it often unmated one end or the other. If the force applied to the connector was great enough, it could damage the fiber cable itself. In either scenario, the network's performance is seriously compromised. Today's MPO connector with the round cable-type is designed to handle the rigors of cable routing and handling. With no cable bend limitations, today's MPO connector ensures greater network reliability.

TE's MPO connector is designed with an integrated strain relief and improved boot design, which delivers superior protection from side-pull forces. This is particularly important in today's outside plant network, where connectors, once installed, need to guarantee uninterrupted performance through the life of the network. Furthermore, these connectors need to hold up to harsh outdoor temperature and conditions - placing further importance on the dependability of the connector. TE's MPO connector is more robust than earlier versions, because it is designed for superior durability and reliability - essential for a component that needs to perform for years anywhere in the network.



TE's MPO Connector

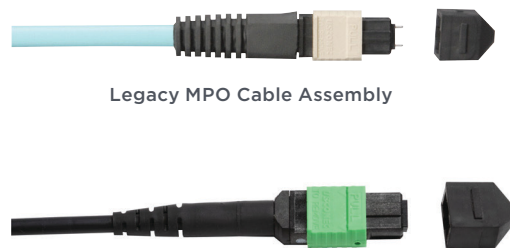

TE's Next Generation MPO Cable Assembly

New Cable Design Delivers Strength, Flexibility

Further enhancing the MPO cable assembly, TE replaced the flat, ribbonized cable with a more flexible, round-cable design. The ribbonized cable was restricted to bending in two directions, where the round cable design allowed for bending in any direction. As a result, technicians are no longer limited where they can route or install an MPO cable assembly. Whether pulled through tight conduit or around sharp corners, the round-cable reduced the bending that can cause attenuation. By ensuring low insertion and return loss, the round-cable design minimizes the impact on link loss budgets. In overcoming the preferential bend issues, the round cable makes routing and handling much easier for technicians, and service providers can use it in more high-density applications.

Tests Verify Significant Improvements in Performance

While the first-generation multifiber MPO often did not meet IEC 61753-1 specifications for single-fiber connectors, the re-designed, next-generation MPO now meets or even exceeds those requirements. During both mechanical stress testing and environmental aging test cycles, the new MPO

cable assembly showed tremendous improvements, in terms of insertion- and return-loss performance.

As illustrated in Figure 1, tests conducted over four operating wavelengths (1310 nm to 1625 nm) revealed the new MPO singlemode connector had a maximum interrelated attenuation of 0.45 decibels (dB) over an operating temperature range of -40°C to +70°C; its average attenuation was less than 0.30dB, and its return-loss performance typically was better than 70dB over the same operating-temperature range.

MPO Connectors Prove Themselves in the Network Core

Although plug-and-play MPO connectors have supported multimode-fiber applications within data centers for some time, many service providers now are starting to use them more in singlemode applications as well. In response, vendors like TE have been working to improve the performance and reliability of MPO connectors. They have also been designing product solutions to more easily incorporate them into the network. In fact, TE produces MPOs for use in applications throughout the CO, using MPO connectors in panel and frame solutions to increase density and speed installation and in distribution-type cables to house higher fiber counts. Because service providers regularly use a single-fiber interface for many of their CO-type applications, multifiber cable assemblies are particularly useful when configured with an MPO connector at one end and a single-fiber cable on the other. For example, if a service provider deploys a piece of equipment with a 24-fiber card, a 24-fiber assembly with two 12-fiber MPO connectors on one end makes much better sense than running 24 individual patch cords, especially when they all run to the same panel.

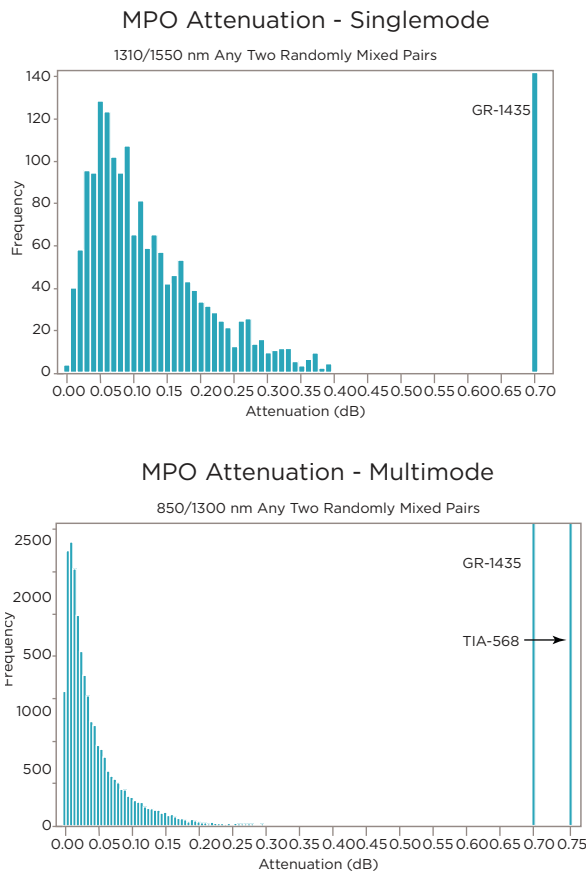

Figure 1

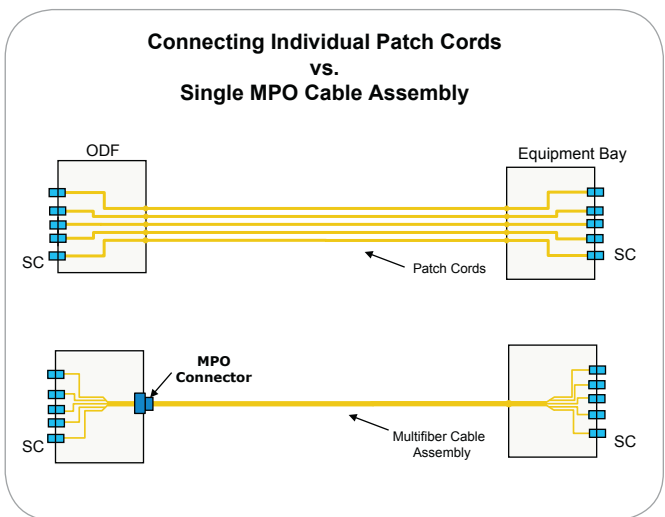

Figure 2

The Value of MPO Cleaning

Although extensive cleaning occurs at the factory before any MPO ships to the customer, following proper cleaning procedures for MPO connectors always will be important. Fortunately, the latest design enhancements have made the cleaning process easier and more effective than ever before. For one thing, cleaning a single MPO connector is faster and simpler than cleaning multiple, individual single fiber connectors. In addition, many cleaning options for MPOs now are available, including inspection scopes and "out of the box" cleaning kits.

Better Performance Ensures Long-term Success

The new and improved next-generation MPO connector now delivers the optical, mechanical and environmental performance that service providers need to expedite the addition of fiber capacity and to support higher data-rate services. Among the numerous operational, financial and competitive benefits of using MPO connectors in the core network are:

- optical insertion loss and return loss performance similar to single-fiber connectors
- maximum space savings for high-density fiber environments;
- reduced labor costs via fast, easy installation-- because one 12-fiber MPO connector replaces 12 single fiber connectors; and
- compliance with standards, i.e., IEC 61754-7; IEC 61755-3-31, IEC 61753-1

With so many service providers around the world now relying on the MPO connector to speed installation and deployment costs throughout their networks, it's clear that the improved, next-generation MPO connector is ready for tomorrow's high speed networks.

WHITE PAPER

Contact us:

Tyco Electronics Raychem bvba
Diestsesteenweg 692
3010 Kessel-Lo, Belgium
Tel: 32-16-351 011
Fax: 32-16-351 697

www.te.com
www.telecomnetworks.com

or your local sales representative



TE Connectivity, TE connectivity (logo), Tyco Electronics, and TE (logo) are trademarks of the TE Connectivity Ltd. family of companies and its licensors.

While TE Connectivity and its affiliates referenced herein have made every reasonable effort to ensure the accuracy of the information contained in this catalog, TE Connectivity cannot assure that this information is error free. For this reason, TE Connectivity does not make any representation or offer any guarantee that such information is accurate, correct, reliable or current. TE Connectivity reserves the right to make any adjustments to the information at any time. TE Connectivity expressly disclaims any implied warranty regarding the information contained herein, including, but not limited to, the implied warranties of merchantability or fitness for a particular purpose. TE Connectivity' only obligations are those stated in TE Connectivity' Standard Terms and Conditions of Sale. TE Connectivity will in no case be liable for any incidental, indirect or consequential damages arising from or in connection with, including, but not limited to, the sale, resale, use or misuse of its products. Users should rely on their own judgment to evaluate the suitability of a product for a certain purpose and test each product for its intended application.

TC 5001/WP/1 02/13